

# ARK-LA-TEX SPEEDWAY

## PROMOD RULES - 2012

**BODY:** Must be Topless. See diagram. Must be same width, front to rear, and parallel to OEM frame. Nose panel must be flat with no fins or scoops allowed. Cooling holes allowed. Nose panel may be no wider, or lower than two inches outside of front frame horns. Nose panel must remain within confines of front bumper. Engine compartment must remain open (no side panels). Hood must be enclosed at rear. No panel in front of right door to engine compartment. No inner panels. May have a rear spoiler maximum 8 inches in material height and maximum 67 inches wide. Side supports no taller than spoiler 12" maximum length.

**DRIVER COMPARTMENT:** Must have minimum three windshield bars in front of driver. Lexan or aluminum cowl panel in front of driver can be no wider than cockpit and no farther back than steering wheel. Minimum 0.125 inch aluminum, or 0.060 inch steel, complete floor pan required. Aluminum high-back seat only and must be bolted in, using minimum 0.375 inch bolts, next to left side frame rail and ahead of rear tires. Bottom of seat can be no lower than bottom of frame rail. Driver must be sealed off from track, driveline, engine, fuel cell, canisters and pumps. Oil coolers must not protrude above interior. Accumulators cannot be mounted between driver and left-side door bars. No driver-adjustable devices allowed while car is in competition except brake adjuster. No mirrors of any kind.

**FRAME:** 1964 or newer OEM perimeter American rear-wheel drive passenger car frame only. No sports car frames. Frame must be full and complete, cannot be widened or narrowed, and must be able to support roll cage on both sides, exceptions are: weight jack in original center line of spring tower allowed; frame may be cut a maximum 36 inches forward from center of rear end housing; horns may be removed in front of steering box front crossmember may be notched and boxed for radiator and/or steering clearance. Maximum two inch wide by four inch tall frame stiffener may be welded directly to outside of left side frame rail. Minimum wheelbase 108 inches, maximum 112 inches, both sides. Maximum overall width shall not exceed 78 inches from outside of tire to outside of tire. For cars using OEM rear suspension design, rear of frame behind rear tires no further forward than one inch behind factory seam, may be replaced with two inch by three inch steel tubing with 0.095 inch wall thickness. No part of frame can be lower than four inches from ground except front crossmember.

**ROLL CAGE:** Must consist of continuous hoops, minimum 1.50 inch O.D. tubing, with minimum wall thickness of 0.095 inch for main cage, framemounted in at least six places. Must consist of a configuration of front, rear and top hoops connected by tubing on sides or side hoops. Driver's head must not protrude outside cage with helmet on. Roll cage must be securely supported and braced with minimum one cross bar in top halo. Foot protection bar required. Main cage no further forward than rear of engine. All bars forward of cage must be lower than hood. All driver side door bars and uprights must be minimum 1.5 inch O.D. Minimum three driver side door bars, parallel to ground and perpendicular to driver, and welded to front and rear of roll cage. Passenger side must have at least one cross door bar, horizontal or angled, minimum 1.25 inch O.D. with 0.083 inch wall thickness, and one top door bar, minimum 1.5 inch O.D. with 0.083 inch wall thickness. Steel door plate, 18 gauge or 0.049 inch minimum thickness, must be securely welded to outside of driver side door bars.

**FRONT SUSPENSION:** All components must be steel, unaltered OEM, in OEM location, and replaceable by OEM parts, exceptions are: tube-type upper A-frames with or without aluminum or steel cross shaft, and mounts can be moved; OEM replacement stamped steel lower A-frames; rubber, nylon or steel lower A-frame bushings, no offset or bearing type; welded or bolted shock mount on lower A-frame; OEM or OEM replacement ball joints allowed. Lower A-frames must be right and left, and of same design. Lower A-frame mounts and bolt holes on frame must be in OEM location. OEM ball joints

only. May use sway bar must be unaltered OEM.

**STEERING:** No rack and pinion. All components must be steel, unaltered OEM, in OEM location, exceptions are: outer tie rod end and adjustment sleeve may be replaced by a minimum 0.625 inch steel rod end and steel tube; spindles can be ground for brake caliper clearance only; bolt on spindle savers allowed; steel steering shafts and knuckles only. Spindles must be right and left, and of same design. OEM Idler arm, pitman arm, and center link must match frame.

**SHOCKS:** One steel, nonadjustable, unaltered shock per wheel only. No shocks allowed on screw jacks. No external or internal bumpers or stops. No coil over, air, or remote reservoir shocks. No Schrader valves or bladder type valve allowed.

**REAR SUSPENSION:** One steel coil or multi-leaf (rear) spring per wheel only. Minimum 4.5 inches O.D., nonprogressive coils only. No torsion bars, air bags or inner liners. All components must be steel. All mounts and brackets must be welded or bolted solid. Coil springs must remain vertical and over center line of rear-end housing. No coil-over eliminators allowed. No chains, cables or tethers. Rear shocks cannot be mounted on control arms. Must utilize one of the following designs: (A) Aftermarket three link design requirements: Must use 15 inch minimum, 24 inch maximum lower control arms. Must use one upper control arm, solid tube only. Must use minimum 21 inch panhard or J Bar. Lower spring perch must be welded to rear-end housing must be center over axle tube. Must use steel upper weight jack. No floating or bearing rear spring perches/cups allowed. (B) Multi-leaf spring design requirements: Must use steel multileaf springs with no additional suspension components besides one shock per wheel. Adjustable aluminum lowering blocks allowed. (C) OEM stock design requirements: Rear crossmember, control arm mounts and bolt holes on frame must be in stock location. Springs must remain in stock location. Lower spring perch must be welded to rear-end housing. Must use steel upper weight jack.

**REAR END:** Any steel approved OEM passenger car or truck non-cambered rear end (housing and carrier) allowed, must be centered in chassis. All components must be steel, except lowering blocks, axle cap, and drive flange. Safety hubs (floater) allowed. No quick change devices.

**BUMPERS:** Steel bumpers must be on front and rear at all times and welded, or mounted with minimum .375 inch bolts. Rear bumper must be constructed of solid square, or minimum 1.25 inch O.D. tubing with 0.095 wall thickness, and no wider than five inches outside of rear frame rails. If wider than five inches outside rear frame rails, must be capped and bent forward 90 degrees, or constructed in a loop design. Must have at least one upright, minimum 1.25 inch with 0.065 wall thickness, from bumper to fuel cell guard. Two-bar front bumper must be minimum 1.25 inch O.D. tubing with minimum 0.065 wall thickness (maximum 0.095 inch) mounted frame-end to frame-end, no wider than width of material outside frame horns and with bottom loop parallel to ground. Top bar must be directly above bottom bar, minimum 6.5 inches apart, measured center to center.

**TIRES/WHEELS:** Must use unaltered Hoosier 2045's or F40's pulloffs only. No chemical softening, conditioning, or grooving of tire. No re-caps allowed. All wheels must be steel, 8" or 10" wide. No bleeder valves, bead lock, on right rear only. Must use only steel bolts. One foam type or plastic mud cap allowed on right rear only. Inner mud cover allowed on left rear only. Must use minimum one inch O.D. Steel lug nuts.

**BRAKES:** Must be steel approved OEM, operative four wheel, drum or disc. Must maintain minimum OEM dimensions for hubs/rotors and calipers, cannot be lightened. Bolt pattern may be changed. Larger studs allowed. Rear rotors may be aftermarket 0.81 inch thickness (new). Vented rotors only, no scalloped or ceramic coated rotors. One proportioning device allowed front to rear only. Rear caliper brackets must be welded or bolted solid to rearend housing.

**EXHAUST:** Round tube headers only. All primary header tubes must enter directly into one collector,

at same point, at end of header. Turn down allowed. No heat wrap, or exotic coatings on headers. Schoenfeld mufflers, stamped IMCA 609, must be used. All exhaust must go through mufflers, two per car, one per header. No exhaust sensors, merge collectors, cross-overs, extensions, inserts or balance tubes.

**FUEL SYSTEM:** Racing fuel cell required, maximum 32 gallon capacity must be in minimum 20 gauge steel container. Cell must be securely mounted behind rear axle .Must mount with minimum two solid steel straps around entire cell, two inches wide and 0.125 inch thick. All cell mounts must be steel, securely welded to frame/cage. Protective tubing must cover rear and extend past both sides of cell. No part of cell shall be lower than protective tubing. Fuel cell vents, including cap vent, must have check valves. If fuel cell does not have aircraft style positive seal filler neck/cap system - a flapper, spring or ball type filler rollover valve is required. Pick-up must be on top or right side of cell. Limit of one fuel filter. Mechanical OEM type push rod fuel pumps only. Any single carb. Gas or methanol.

**BATTERY/STARTER:** One 12 volt battery only.

**GAUGES/ELECTRONICS:** 12 volt ignition system only. No electronic traction control.

**TRANSMISSION:** Automatic or Manual. If using Bert or Brinn type or mini clutch, direct drive coupler, car and driver must weigh 2,400 lbs. after race. Minimum two inch diameter, white, steel drive shaft. Steel slip yokes only. 360-degree drive shaft loop required and must be constructed of at least 0.25 inch by two inch steel, or one inch tubing, mounted six inches back from front Ujoint. With engine running and car in still position, driver must be able to engage car in gear and move forward, then backward. No 'in and out' boxes or quick change devices allowed.

**ENGINE COMPARTMENT:** Rear of engine (bellhousing flange) must be mounted at least 72 inches forward from centerline of rear axle. Stock rear suspension mounts may be at 70" Engine offset must be kept within two inches of centerline of front crossmember with engine level. Copper/brass or aluminum radiator only and must be mounted in front of engine. OEM steel passenger vehicle production block only. 'Wet' sump oiling system only. Steel oil pans only. Steel heads only. Any stud mounted rocker arm. Aftermarket aluminum intakes allowed.

**WEIGHT:** Minimum weight limit of 2,350 lbs. cars using Brinn type or mini clutch, direct drive coupler must be 2,400 lbs. Weights must not be used in driver compartment or outside body. All weights must be securely mounted with at least two 0.5 inch bolts, painted white with car number on it. No titanium, magnesium, stainless steel or carbon fiber components. Solid steel fasteners only.

**COURTESY RULE:** Any car with "minor" rule infractions will be allowed to race (1) event. Cars with infractions are subject to weight penalty.

Questions Call 318-218-9430

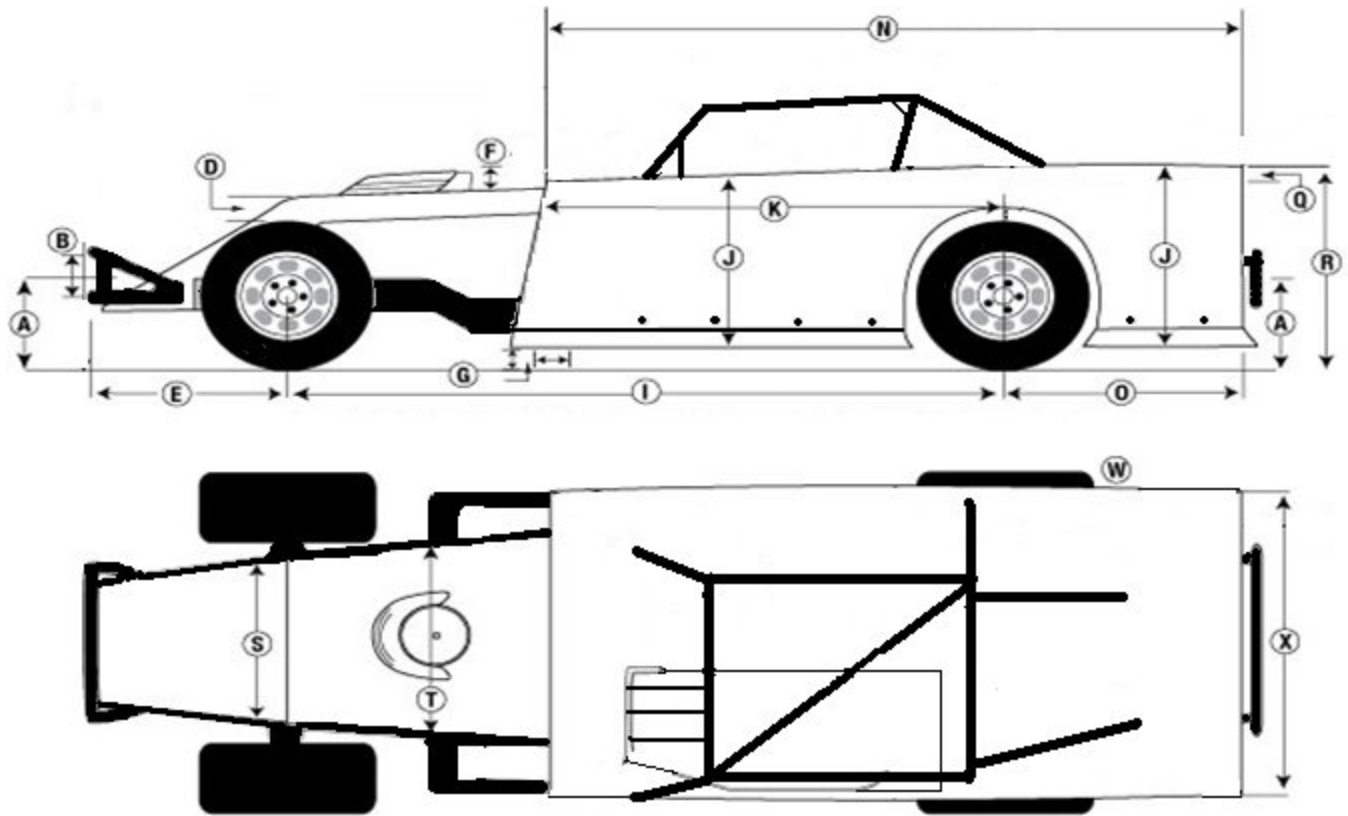

- A. 23" max. 16" min. (ground to center of bumpers, front and rear)
- B. 6.5 min. (center to center)
- D. Hood 6" max. drop (sides) sealed off from drivers compartment and max. 3" rake.
- E. 42" max.
- F. 6" max. scoop cannot extend past front of hood.
- G. 4" min. Door may extend max. 6" past block at bottom on both sides.
- I. 112" max. 108" min.
- J. 31" max. 22" min.
- K. 72" max or not past back of block at top. Left side may extend forward to cover foot box if necessary.
- N. 121" max. 98" min.
- O. 48" max. 31" min.
- Q. Interior slope is 6" max. front to rear and flat across. If flat at front half of interior you have used up 50% of your 6", therefore behind driver to rear you may only have 3". Top of interior must be flush with top of door and quarter panels.
- R. 41" max. 28" min.
- S. Min. 24" nose must be flat and flush with sides.
- T. 67" max. 32" min.
- W. Tires must be widest part of car on both sides.
- X. 67" max. 53" min. measured at top of interior deck, must be same front to back.