

# ARK - LA - TEX SPEEDWAY

## 2011 OPEN WHEEL MODIFIED RULES

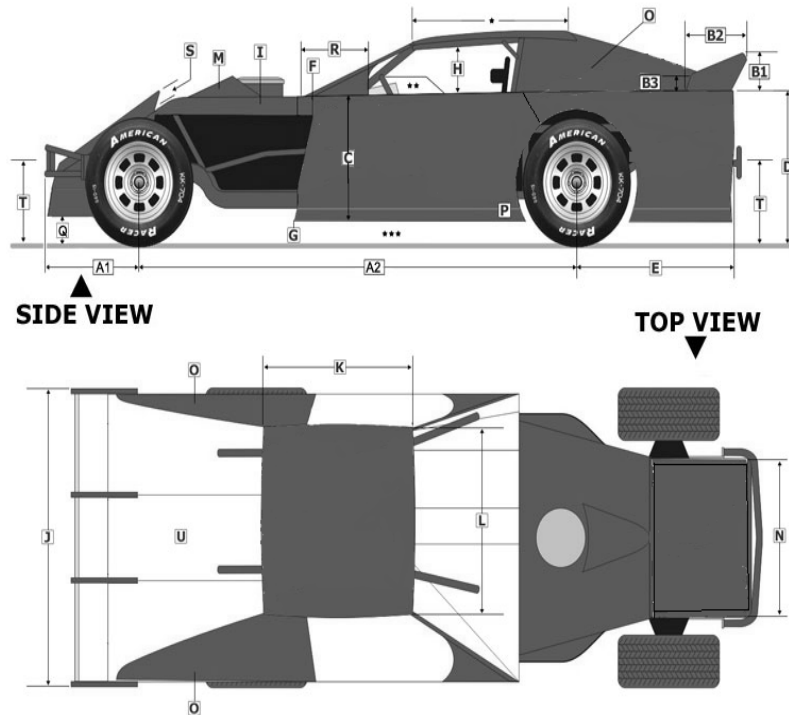

- A1. Maximum 42".
  - A2. Minimum 108".
  - B1. 6" Maximum
  - B2. Maximum 20" long; Maximum 2" above and 2" behind spoiler (maximum 2 center and 2 side)
  - B3. Maximum 3" tall from deck lid to end of angle. No square or rectangular supports.
  - C. Minimum 22"; Maximum 30".
  - D. Maximum 38".
  - E. Minimum 34"; Maximum 48".
  - F. Top of door and deck to rear of block.
  - G. Maximum 8" forward from rear of block.
  - H. Minimum 12"; Maximum 18".
  - I. Maximum 4" sides; Maximum 3" slope.
  - J. Minimum 53"; Maximum 66" (must be same front)
  - K. Minimum 40"; Maximum 56".
  - L. Minimum 44"; Maximum 50".
  - M. Maximum 6" high.
  - N. Maximum 40" (must be inside bumper braces).
  - O. Sail panels must be same on both sides.
  - P. Maximum 6" plastic skirt.
  - Q. Maximum 7".
  - R. Maximum 20".
  - S. Maximum 2", bent same (both in and out) and flush with hood.
  - T. Minimum 16" and maximum 20" from ground.
  - U. Deck must remain flat from side to side, except for cockpit (maximum 10" rake from front to rear). If doors remain flat, only maximum 5" rake permitted.
- \* Maximum 5" front clearance and 2" rear clearance using 4' level.
  - \*\* Driver may be asked to exit right side of car with helmet on if Official deems interior shield to be too large or otherwise unsafe.
  - \*\*\* Minimum 3" from ground to body; Minimum 4" from ground to frame.

### Spoiler Brace

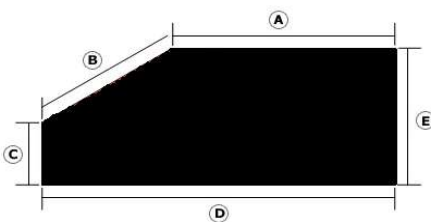

- A: 12" Maximum.
- B: 12" Minimum.
- C: 3" Maximum.
- D: 20" Maximum.
- E: 6" Maximum

All spoiler supports must be of the same shape with a maximum of four supports. No mixing of the two outside supports. Metal braces in center are permitted. Spoiler must mount to deck. Supports may extend a maximum 2" above and maximum 2" behind spoiler.

### BODY:

1970 or newer American passenger cars only. No panel vans or station wagons. Stock appearing front window support units must be used.

A minimum window opening of twelve (12) inches must be maintained on both side window openings. Original roof line of vehicle must be maintained with a maximum of five (5) inches of slope from rear to front. No more than one-half (1/2) inch stiffener allowed at the rear of the roof and must turn down perpendicular to the ground. O.E.M. Gremlin roofs are not allowed.

Sail panels must be of matching design with matching styles on both sides of racecar. No belly pans. A belly pan will be defined as any object or material that

alters the airflow under the racecar. No panel in front of the right door next to the engine compartment.

### **Spoilers:**

**A maximum rear spoiler height of six (6) inches of total material will be allowed.** Rear spoiler may not exceed the width of the rear deck lid. A maximum of four (4) supports may be installed on the front of the rear spoiler. Supports may extend to a maximum of two (2) inches above and a maximum of two (2) inches behind the top of the rear spoiler. Supports may be a maximum of twenty-four (24) inches in total length.

**A maximum two (2) inch tall fin is allowed on each side of the nosepiece.**

Side panels enclosing the engine compartment are allowed for decal placement only, and may not extend further back than the back of the block. Side panels must be easily removed for inspection of racecar at any time.

The rear deck lid and/or trunk area must be covered. Aluminum roofs are allowed. Doors and quarter panels may be mounted a maximum of one (1) inch above the deck. Excluding hood and nosepiece, the top of the body should extend no further forward than the back of the engine block. The bottom of the body may extend up to twelve (12) inches forward of the back of the engine block.

### **Numbers:**

Must be on the top and both sides. Must be at least 20" tall.

### **Bumpers:**

Both front and rear bumpers must be used, and must not have any sharp edges. Any inappropriate bumper will be disallowed by an official. Front bumper should be mounted from frame-end to frame-end with the bottom loop parallel to ground. Bumpers must be made of a minimum of one and one-quarter (1-1/4) inch tubing and must be able to support the racecar if lifted by a tow vehicle. Rear bumpers may be constructed of tubing or flat stock, and must protect the fuel cell. Center of bumpers (both front and rear) must be at least sixteen (16) inches from the ground and no more than twenty (20) inches from ground. Rear bumpers may be no more than two (2) inches wider than the body on each side and may not be open-ended (must wrap around and be connected to side rail bars). Overall width of the racecar may not exceed 78 inches. Width shall be measured from the widest points on each side of the racecar.

### **ROLL CAGES:**

Round steel tubing, seamless roll-over bars are required for the basic roll cage, and must be acceptable to officials. Acceptable tubing is as follows: one and three-quarters (1-3/4) inches by nine-tenths (.090) of an inch or one and one-half (1-1/2) inches by ninety-five one-hundredths (.095) of an inch for mild steel and DOM tubing (one and three-quarters (1-3/4) inches by eighty-three one-hundredths (.083) of an inch for chrome-moly tubing). Aluminum and/or other soft metals are not allowed. Roll bar connections must be properly welded. Roll bars within the driver's reach must be padded with an accepted material as determined by an official. Fire retardant material is highly recommended. Must be frame-mounted in at least six (6) places. Must have a protective screen or bars in front window

opening in front of driver's face. Brace bars forward of roll cage may not be higher than the stock hood height x eighty-three one-thousandths (.083) inch for hood height. A minimum of three (3) driver side door bars must be parallel to ground and located perpendicular to the driver so as to provide maximum protection for the driver, but without causing undue difficulty in getting in or out of the racecar. Side bars must be welded to the front and the rear of the roll cage members. Door bars with a thickness of less than nine-tenths (.090) of an inch should have four (4) bars at least one and one-half (1-1/2) inches in diameter at a minimum of eighty-three one-hundredths (.083) of an inch thickness and be gusseted in place. The door bars must have six (6) vertical studs per side of one and three-quarters (1-3/4) inches by eighty-three one-hundredths (.083) of an inch minimum seamless round tubing equally spaced.

### **FRAME:**

Factory production complete full 1960 or newer parallel American passenger car frames only. Frames may be cut in rear only at a point not further than thirty-six (36) inches from center of rear end housing. Must be full and complete on both sides, may not be widened or narrowed and must be able to support roll cage on both sides. Minimum height from ground is four (4) inches. Exception: Front cross member may be notched for radiator clearance only. No front-wheel-drives allowed. Rear of frame may be altered to accept leaf or coil springs. No hydraulic, ratchet or electric weight jacks anywhere on the racecar. Aluminum jack bolts are not allowed. Minimum wheelbase must be one-hundred eight (108) inches on both sides (no tolerance). Maximum overall width of car (at front or rear) shall not exceed seventy-eight (78) inches from outside of tread to outside of tread (no tolerance).

### **COCKPIT :**

Rear view mirrors are not allowed. Floor and firewall must be complete in the driver's compartment. No interior sheet metal can be higher than or enclose a standard window opening. Sheet metal in the driver's compartment must be horizontal from the top of the driver shaft tunnel to the right side door bars or angle from the top of the drive shaft tunnel upwards to the top of the right side door bars. Driver must be able to exit the racecar from both sides. Any driver caught with a double firewall in cockpit is subject to deeper inspection.

### **Steering:**

Must be O.E.M. and remain within original bolt pattern for type of frame used. Rack and pinion is not allowed. May be modified to suit driver, but must remain on left side of cockpit (no center steering).

### **SUSPENSION:**

Must remain stock-type for the type of frame being used. Steel aftermarket parts may be used as stock components as long as they mount in the stock location and are the same size as the O.E.M. parts.

**No aluminum or titanium components allowed.** Magnet must stick to all components. Steel tube-type upper A-frames allowed and can be moved.

Aluminum cross shafts and wedge tubes are permitted. Stock passenger car spindles only - no fabricated spindles. Front sway bars may be used. Front sway

bars must be made of steel and may be attached to the bottom A-frame using steel heim joints. Sway bars must be solid full-length O.E.M.

Rear panhard bars may be used. Rear panhard bars must be made of steel and may be attached by using a minimum three-quarter (3/4) inch i.d. steel heim joint.

**Steel coil-over eliminators or steel/aluminum coil-over kits are allowed, but must conform to shock and spring rules.**

Suspension or rear end parts must be steel. Aluminum mounting brackets are permitted. Shocks & Springs:

**One shock per wheel only. Aluminum Heims on shocks are not allowed. Steel Only.**

Air shocks are not allowed. All coil springs must be at least four and one-half (4-1/2) inches outside diameter. Steel springs only. No torsion bars allowed in rear. Canister shocks are not allowed.

## **ELECTRICAL SYSTEM:**

### **Battery:**

Must be securely mounted. One (1) 12-volt or 16-volt battery only.

### **Ignition:**

Magnetos or crank-triggered ignitions are not allowed. No more than one (1) coil may be used. Kill switch required within easy reach of the driver. The switch must be clearly marked off and on.

**Digital tachometers are permitted. At the discretion of officials, MSD boxes may be confiscated.**

All wiring must be accessible for inspection. Any driver caught with extra wiring may be suspended and/or disqualified.

## **FUEL SYSTEM:**

### **Fuel:**

Must be automotive gasoline or alcohol. No additives of any kind. May not be blended with ethers or other oxygenates, and may not be blended with aniline or its derivatives, nitro compounds or other nitro containing compounds. Electric fuel pumps are not allowed.

### **Carburetor:**

One (1) two-barrel, one (1) four-barrel or one (1) Predator carburetor

Must be naturally aspirated. No fuel injection.

**Fuel cell:**

Must be commercially manufactured and must be mounted utilizing at least two (2) steel straps. Straps must be two (2) inches wide at all measuring points. Must be enclosed in a steel container and must be protected in rear of axle by roll cage tubing mounted securely. No part may be lower than protective tubing. Protective tubing must be no wider than six (6) inches on both sides. Must have check valves. Limited to a maximum capacity of thirty-two (32) gallons.

**TIRES & WHEELS:****Wheels:**

Must be fifteen (15) inches in diameter and eight (8) inches in width.

Must be reinforced steel only. A steel or aluminum bead lock may be used on the right side wheels only, and may be mounted on the outside of the wheel so long as it does not add over three-quarters (3/4) of an inch to the overall width of the wheel. Homemade mud caps are not allowed. Wheel covers are allowed on right side wheels only. Wide five wheel adaptors are not allowed. Steel or aluminum spacer between hub and wheel is allowed, but overall width of racecar cannot exceed seventy-eight (78) inches.

**Aluminum or steel lug nuts are allowed.**

**Tires:**

**American Racer KK-704 or Hoosier G-60 tires are allowed. All non-stamped tires must be asphalt (no dirt).**

Softening is not allowed. Any driver caught softening tires shall be fined, suspended and shall receive no points or money. **Grooving and siping is allowed.**

Recaps are not allowed.

**BRAKING SYSTEM:**

Must be operating on all four wheels and must lock up all four wheels during inspection. Must have caliper and rotor on all four wheels. Vented rotors are required on front wheels. Electronic brake actuators are not allowed.

Calipers may not be lightened and must be O.E.M. Rotors must be steel and may not be lightened or drilled. Rotors may be re-drilled for different bolt patterns or larger studs.

**DRIVE SHAFT:**

A loop is required and must be constructed of at least one-quarter (1/4) inch by two (2) inch solid steel. Loop must be mounted no more than six (6) inches from the front of the drive shaft tube. Alternatively, two (2) loops of one-quarter (1/4) inch by one (1) inch solid steel fastened to cross member are allowed. Must be painted white and made of steel.

## **TRANSMISSION:**

Must all be clutch-operated. Bert and Brinn transmissions are allowed. With motor running and racecar in stationary position, driver must be able to engage racecar in gear and move forward, then backward, at time of inspection. One (1) forward gear and one (1) reverse gear must be in working order, plus a neutral position, and must be able to be shifted by driver. Clutch-type transmissions must be equipped with an explosion-proof steel bell housing. Aluminum must be SFI-approved (GM bell housing is not SFI approved).

**Automatic, Bert or Brinn transmissions must have a guard two-hundred seventy**

**(270) degrees around flex plate or flywheel, and must be constructed of at least one-quarter (1/4) inch steel. Alternatively, automatic transmissions may utilize an SFI-approved aftermarket guard.** All racecars must have the capability of starting without being pushed or pulled.

## **REAR END:**

Any steel approved OEM passenger car or truck rear end (housing and carrier) allowed. Safety hubs (floater) allowed. All components must be steel, except lowering blocks, axle cap, drive flange. Inspection hole required in housing. Full steel spool, steel mini spool or welded rear ends only. Steel axles only. No cambered rear ends. Quick Change rear ends OK. One piece drive flange only. No torque dividing differentials. No scalloped ring gears.

No traction devices allowed (includes Gold Track, True Track or similar type components).

## **ENGINE:**

Must be able to be used in conventional passenger car without alteration. Motor mounts may not be removed or altered. Castings and fittings may not be changed. Machine work on outside of engine, or on front or rear of camshaft, is not allowed.

No total dry sump systems allowed. Wet system must be operative.

Cooling system may be modified. Radiators and oil coolers must not protrude above interior.

Any American make may be used. Rear of engine (bell housing flange) must be mounted at least seventy-two (72) inches forward from the center line of the rear axle, if using stock rear cross member & suspension mounts may be at 70"- no tolerance.

Offset must be within two (2) inches of centerline of front cross member.

Steel blocks only. No aluminum or titanium.

Radiator must be mounted in front of engine.

### **Mufflers are mandatory!**

#### **WEIGHT:**

The minimum overall racecar weight shall be two-thousand three hundred and fifty (2,350) pounds. If utilizing aluminum heads, racecar must have fifty (50) pounds in front of mid-plate.

#### **Ballast:**

May not be mounted in cockpit, or outside of body or hood area.

Must be securely mounted, painted white and clearly marked with the car number. Must be attached with at least two (2) one-half (1/2) inch bolts.

May not be attached to rear bumper.

#### **SAFETY:**

It is recommended that each racecar have built-in fire extinguishing equipment, but cannot be of the dry powder type (must be Halon 1211 or equivalent). Drivers should have in their pit area as part of their equipment, at all times, a fully charged dry chemical, Halon (or its equivalent) fire extinguisher. Ten (10) or thirteen (13) pound fire extinguishers are highly recommended. Driver must wear required helmet, fire suit and five-point safety harness whenever the racecar is on the racetrack. This includes during track packing, warm ups, hot laps and races.

Helmets are mandatory and must be an approved SHCA or Snell-type full coverage. Helmets should accompany driver and racecar at time of inspection. Helmets of at least Snell SA2000 or SA2005 rating are mandatory. Fire-resistant gloves are mandatory. Fire-resistant shoes are highly recommended. Five-point safety belts, sub-belt and shoulder harness is required. Shoulder harness must be mounted securely to the roll cage. It is recommended that seat belts and shoulder harnesses not to be more than one (1) year old. Where the belt passes through the seat edges, it must have a grommet installed, be rolled and/or padded to prevent cutting of the belt.

**Full-size window net mounted in the left side driver's window opening and/or approved racing arm restraints are required.** Window net mounts must be welded to the roll cage. All bars around the driver must have approved roll bar padding. If driver is utilizing arm restraints and official can pull driver's arm out of cockpit, driver will not be allowed to compete. Fire-resistant safety neck collars are mandatory.